

**International General Certificate of Secondary Education
CAMBRIDGE INTERNATIONAL EXAMINATIONS**

PHYSICS

0625/5

PAPER 5 Practical Test

CONFIDENTIAL INSTRUCTIONS

OCTOBER/NOVEMBER SESSION 2002

1 hour 15 minutes

Great care should be taken that any confidential information given does not reach the candidates either directly or indirectly.

Instructions for preparing apparatus

The teacher responsible for preparing the examination is **not** allowed to consult the question paper before the examination. Teachers should, as a part of the preparation of the examination requirements, perform the tests indicated on pages 3–6 in order to satisfy themselves that the supplied materials are satisfactory.

N.B. The candidates will be instructed not to write out a detailed description of the apparatus; instead, the Supervisor or teacher responsible is asked to give (and attach to the Report form printed on pages 7 and 8) a *brief* description of the apparatus supplied, mentioning any points that are likely to be of importance to the Examiner in marking the answers. The Supervisor should also report any assistance given to candidates under the regulations explained on page 2. All reports should be signed by the Supervisor and by the person responsible for preparing the apparatus.

In addition to the usual equipment of a physics laboratory, each candidate will require the apparatus specified on pages 3–6. If a candidate breaks any of the apparatus, or loses any of the material supplied, the matter should be rectified and a note made in the Report.

If you have any problems or queries regarding these Instructions, please contact CIE

by e-mail: International@ucles.org.uk,

by phone: +44 1223 553554,

by fax: +44 1223 553558,

stating the Centre number, the nature of the query and the syllabus number quoted above.

These instructions consist of 8 printed pages.



Instructions for the Practical Physics Supervisor

A Assistance to Candidates

The purpose of the Practical Physics test is to find out whether the candidates can carry out simple practical work themselves. The Examiners are aware that candidates may sometimes be unable to show their practical ability through failure to understand some point in the theory of the experiment. If an Examiner were present in the laboratory, he would be willing to give a hint to enable such a candidate to get on with an experiment. In order to overcome this difficulty, the Supervisor is asked to co-operate with the Examiners to the extent of being ready to give (or allow the Physics teacher to give) a hint to a candidate who is unable to proceed.

The following regulations must be strictly adhered to.

- (i) No hint may be announced to the candidates as a whole.
- (ii) A candidate who is unable to proceed and requires assistance must come up to the Supervisor and state the difficulty. Candidates should be told that the Examiners will be informed of any assistance given in this way.
- (iii) A report must be made of any assistance given to the candidate, with the name and index number of the candidate.

It is suggested that the following announcement be made to the candidates.

'The Examiners do not want you to waste time through inability to get on with an experiment. Any candidate, therefore, who is unable to get on with the experiment after spending 5 minutes at it, may come to me and ask for help. I shall report to the Examiners any help given in this way, and some marks may be lost for the help given. You may ask me for additional apparatus which you think would improve the accuracy of your experiments, and you should say, on your script, how you use any such apparatus supplied.'

B Number of sets of apparatus

As a *minimum*, the number of sets of apparatus provided should be $N/4$, where N is the number of candidates (per session): a few spare sets should, preferably, be available to avoid any candidate being delayed when moving to another question.

Centres may find it more convenient and easier to administer if $N/3$ sets (plus one or two 'spares') of apparatus are provided.

The order in which a given candidate attempts the four questions is immaterial.

Question 1

Items to be supplied by the Centre (per set of apparatus unless otherwise specified)

- (i) Metre rule
- (ii) 50 g mass (a balance weight or other mass that has uniform density and a regular shape)
- (iii) 200 g mass (a balance weight or other mass that has uniform density and a regular shape)
- (iv) Triangular block to act as a pivot for the metre rule: this block is to stand on the bench. The block should be about 5 cm high, but the height is not critical.

Action at changeover: dismantle the apparatus.

Question 2

Items to be supplied by the Centre (per set of apparatus unless otherwise specified)

- (i) Thermometer: – 10°C to 110°C, graduated in 1°C intervals
- (ii) Beaker: 250 cm³ containing about 200 cm³ water at approximately 80°C
- (iii) Boss, clamp and stand
- (iv) Stopclock

Notes:

1. Candidates will be required to take readings at 30 s intervals. They may use stopclocks or stopwatches or a wall mounted clock with a seconds sweep hand, or their own wristwatch. The question will refer to a stopclock.
2. The beaker of hot water, thermometer, boss, stand and clamp are to be set up for the candidate as shown in Fig. 2.1. The candidates must be able to lift the thermometer out of the beaker of hot water by simply moving the stand and not removing the thermometer from the clamp.
3. Candidates should be warned of the dangers of burns or scalds when using very hot water.

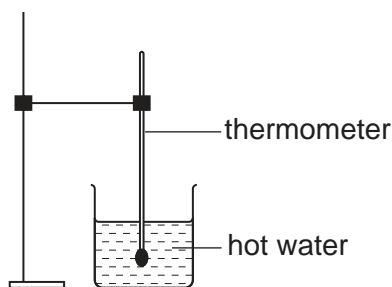

Fig. 2.1

Action at changeover: replace the hot water and check that the apparatus is set up as in Fig. 2.1.

Question 3

Items to be supplied by the Centre (per set of apparatus unless otherwise specified)

- (i) Power source of approximately 1.5 V – 2.0 V. Where candidates are supplied with a power source with a variable output voltage, the voltage setting should be set by the Supervisor and fixed (e.g. taped).
- (ii) 2 similar lamps in suitable holders: any low voltage bulbs will suffice, provided that they glow when connected in parallel with the power supply.
- (iii) Switch
- (iv) Ammeter: full-scale deflection 0.5 A or 1.0 A
- (v) Voltmeter: full-scale deflection 1.5 V or 3.0 V
- (vi) Sufficient connecting leads to construct the circuit shown in Fig. 3.1

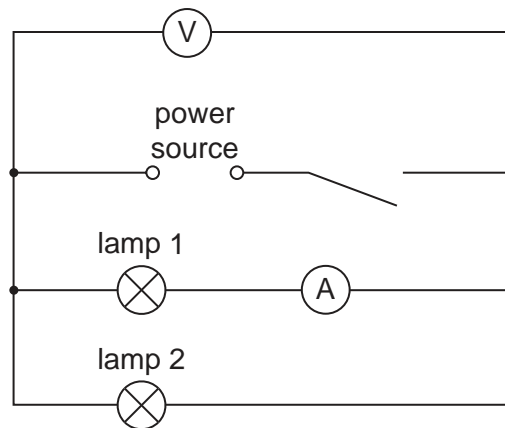

Fig. 3.1

Notes:

1. The components should be connected as shown in Fig. 3.1.
2. The lamps should be labelled 'lamp 1' and 'lamp 2'.
3. The candidates will be required to disconnect the ammeter and reconnect it in series with lamp 2. The circuit should be arranged so that this can be done without difficulty.

Action at changeover: reconnect the circuit as shown in Fig. 3.1.

Question 4

Items to be supplied by the Centre (per set of apparatus unless otherwise specified)

- (i) Converging lens, focal length 150 mm, with a suitable holder
- (ii) Illuminated object with a small triangular hole (see Fig. 4.1 and Fig 4.2). The hole is to be covered with thin translucent paper (e.g. tracing paper).
- (iii) Metre rule
- (iv) 300 mm or 150 mm rule
- (v) Screen. (A white sheet of stiff card approximately 150 mm \times 150 mm fixed to a wooden support is suitable. See Fig. 4.3.)

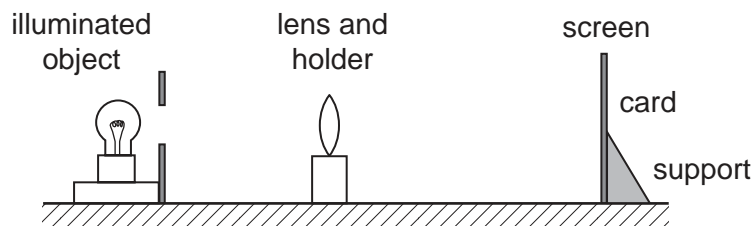

Fig. 4.1

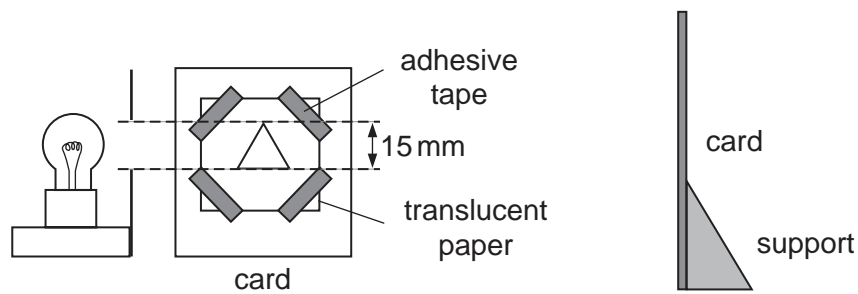

Fig. 4.2

Fig. 4.3

Notes:

1. The lamp for the illuminated object should be a low voltage lamp, 24 W or higher power (a car headlamp bulb is suitable), with a suitable power source.
2. The centre of the hole that forms the object, the lamp filament and the centre of the lens in its holder are all to be at the same height above the bench.
3. The illuminated object and screen must be fixed to the bench (e.g. with adhesive tape) so that the distance between them is 800 mm.
4. The lens and holder should be placed about 50 mm from the illuminated object.
5. The apparatus should be situated away from direct sunlight.

Action at changeover: check that the lens and holder are 50 mm from the illuminated object.

This form must be completed and returned with the scripts.

REPORT ON PRACTICAL PHYSICS

(IGCSE NOVEMBER 2002)

General

The Supervisor is invited to give details of any difficulties experienced by particular candidates giving their names and candidate numbers. These should include reference to:

- (a) difficulties due to faulty apparatus;
- (b) accidents to apparatus or materials;
- (c) any other information that is likely to assist the Examiner, especially if this cannot be discovered in the scripts;
- (d) any help given to a candidate.

Information required

A plan of workbenches, giving details by index number of the places occupied by the candidates for each experiment for each session, must be enclosed with the answer booklets.



Information required (cont.)

A list by name and index number of candidates requiring help, with details of the help provided

CENTRE NO.

NAME OF CENTRE

Declaration (to be signed by the Principal)

The preparation of the practical examination has been carried out so as to maintain fully the security of the examination.

SIGNED